

ON LINE HYDRANT NOTES

1. ALL DIMENSIONS IN MILLIMETRES (mm) UNLESS NOTED OTHERWISE.
2. HYDRANT CHAMBERS SHALL BE COVERED WITH APPROVED HEAVY DUTY METAL COVERS TO IS 261 OR BS 5834 COVER AND FRAME SHALL BE SUITABLE FOR ROAD AND TRAFFIC CONDITIONS AND IS SUBJECT TO REVIEW BY IRISH WATER.
3. ALL HYDRANTS SURFACE BOX FRAMES & COVERS SHALL COMPLY WITH THE RELEVANT PROVISIONS OF IS EN 14339, IS EN 1074-6 & BS 750. FIRE HYDRANTS SHALL BE TYPE 2. THE HYDRANT INLET SHALL BE 80mm DIAMETER WITH PN16.
4. ALL HYDRANTS SHALL BE CLOCKWISE CLOSING.
5. HYDRANT CHAMBER TO BE CONSTRUCTED OF PRECAST CONCRETE UNITS OR HIGH DENSITY BLOCKWORK. ALTERNATIVELY PROPRIETARY PREFABRICATED CHAMBER UNITS MAY ALSO BE USED. SUBJECT TO REVIEW BY IRISH WATER. ROOF SLABS SHALL BE DESIGNED TO CARRY ALL LIVE LOADS & DEAD LOADS, & CONSIST OF A REINFORCED CONCRETE SLAB OF IN-SITU CONCRETE, GRADE C30/37, WITH A MINIMUM THICKNESS OF 150mm. ALTERNATIVELY, PRE-CAST CONCRETE ROOFS MAY BE USED, SUBJECT TO IRISH WATER REVIEW, & COMPLIANCE WITH BS 5911, Part 4.
6. CONCRETE CHAMBERS SHALL BE SURROUNDED BY A MINIMUM OF 150mm COMPACTED CLAUSE 808 MATERIAL AS PER STD-W-13.
7. DUCTILE IRON PIPES AND FITTINGS TO BE IN ACCORDANCE WITH IS EN 545. PE PIPES AND FITTINGS TO BE IN ACCORDANCE WITH IS EN 12201:2011.
8. 200mm ALL AROUND, 100mm DEEP CONCRETE PLINTH AROUND COVERS IN GREEN AREAS.
9. THRUST BLOCKS (NOT SHOWN ON DRAWING), TO BE PROVIDED AS PER STANDARD DRAWING STD-W-28 AT ALL TEES, BENDS, TAPERS, DEAD ENDS AND PIPES AT STEEP SLOPES.
10. ANTI CORROSION TAPE TO BE PROVIDED AROUND BURIED FLANGES.
11. ALL CONCRETE TO BE IN ACCORDANCE WITH IS EN 206.
12. ANY SPECIAL ROAD REINSTATEMENT AROUND COVER & FRAME SHALL BE TO ROAD AUTHORITY'S REQUIREMENTS.
13. NEW ROAD CONSTRUCTION & SURFACE FINISH TO BE TO ROAD AUTHORITY REQUIREMENTS.
14. EXISTING ROAD REINSTATEMENT TO COMPLY WITH CURRENT VERSION OF "GUIDELINES FOR MANAGING OPENINGS IN PUBLIC ROADS" BY THE DEPT. OF TRANSPORT, TOURISM & SPORT, OR TRANSPORT INFRASTRUCTURE IRELAND REQUIREMENTS.

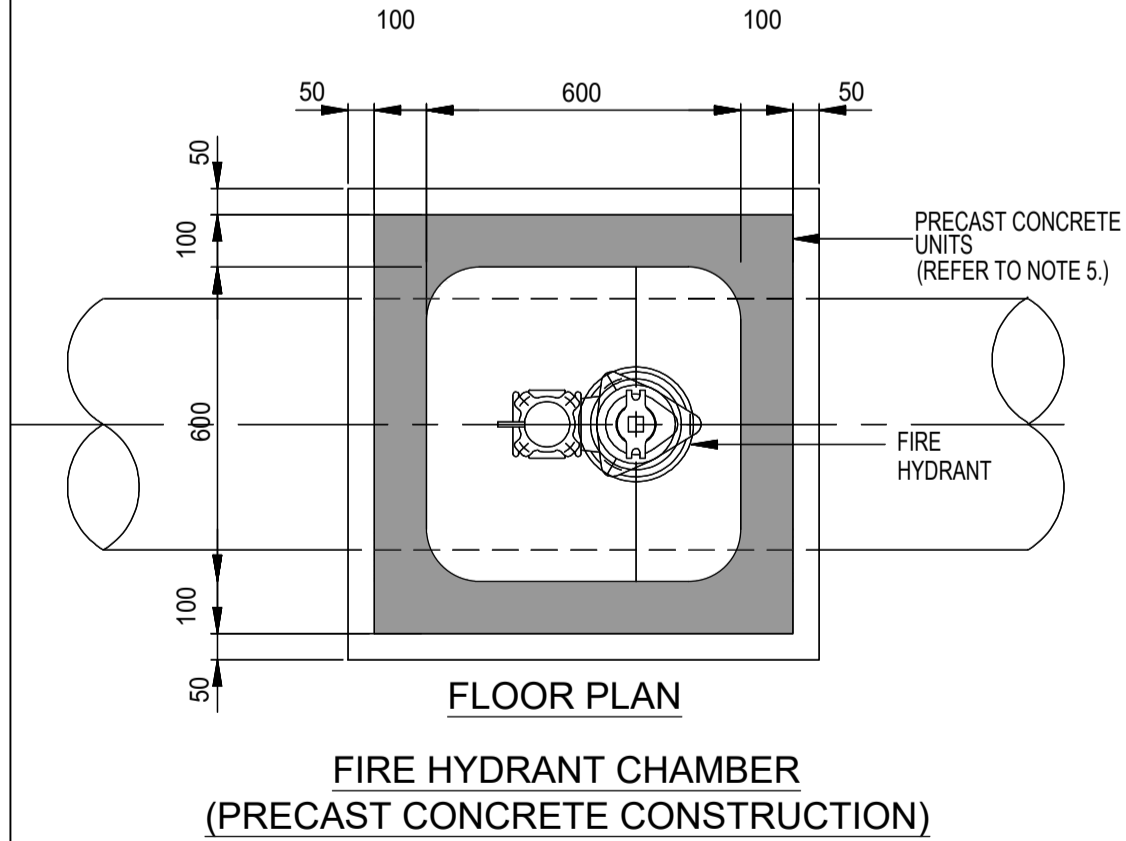

IRISH WATER DETAIL STD-W-18
ON LINE HYDRANT FOR POLYETHYLENE (P.E.) PIPE
SCALE: N.T.S.

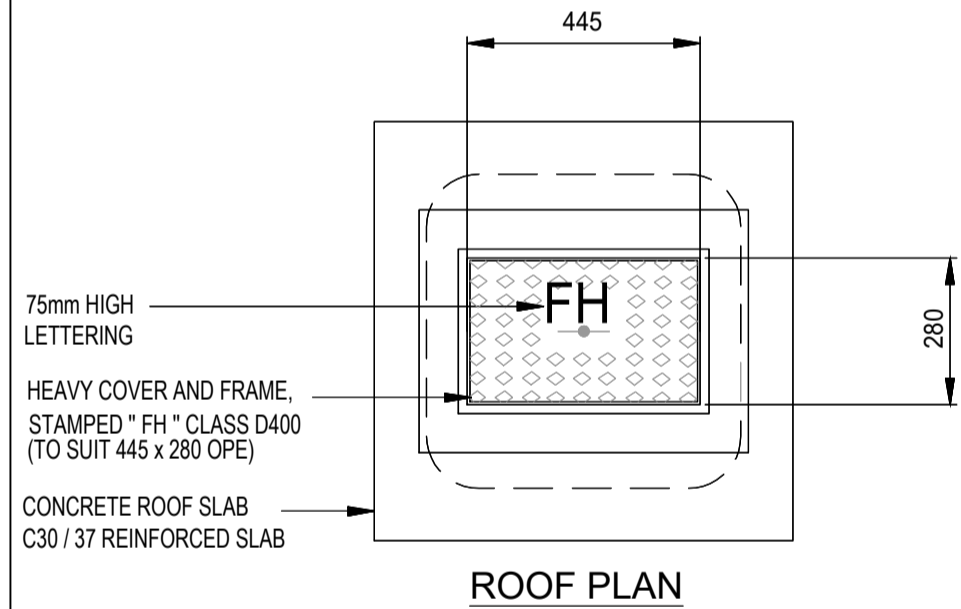
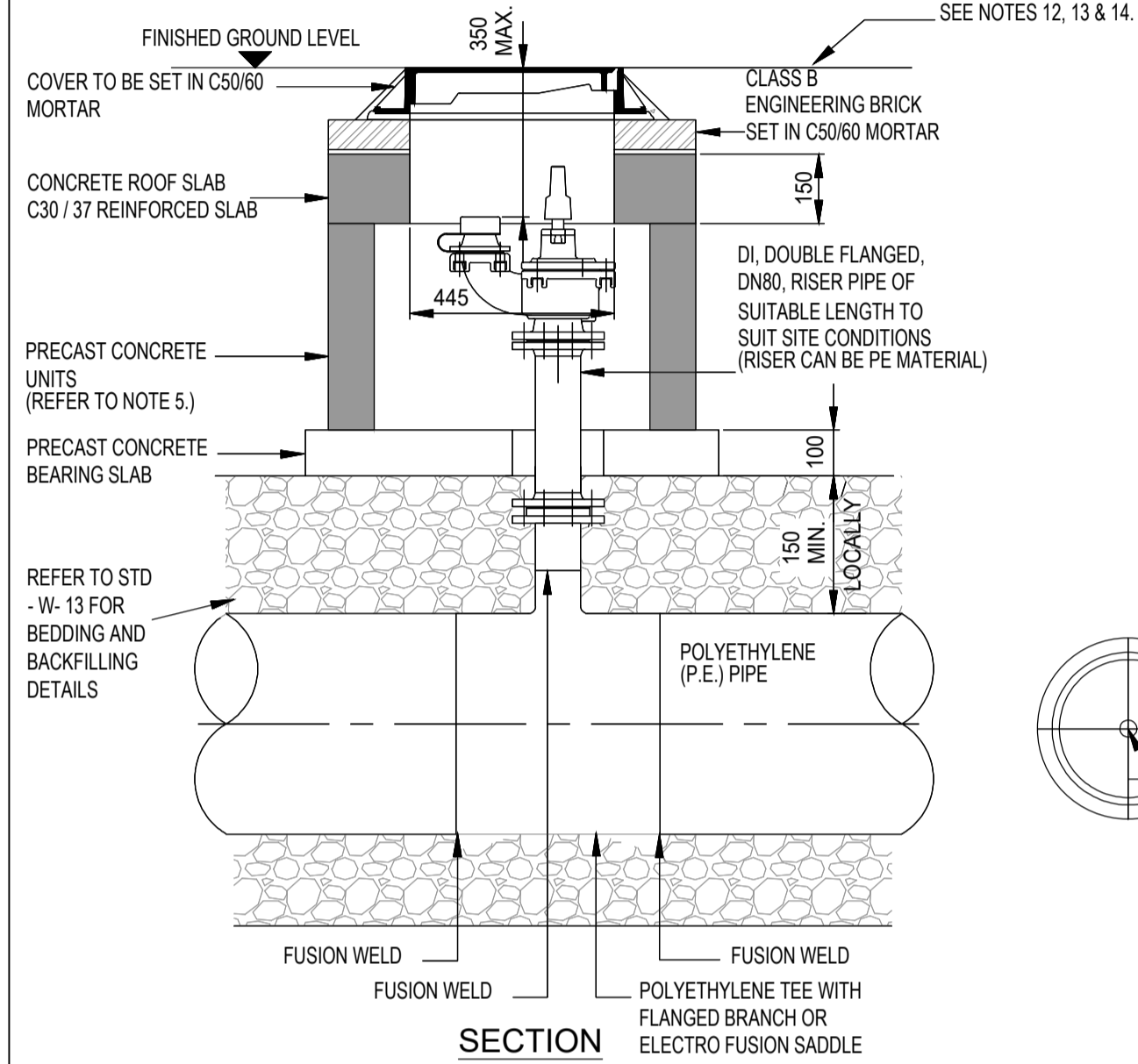
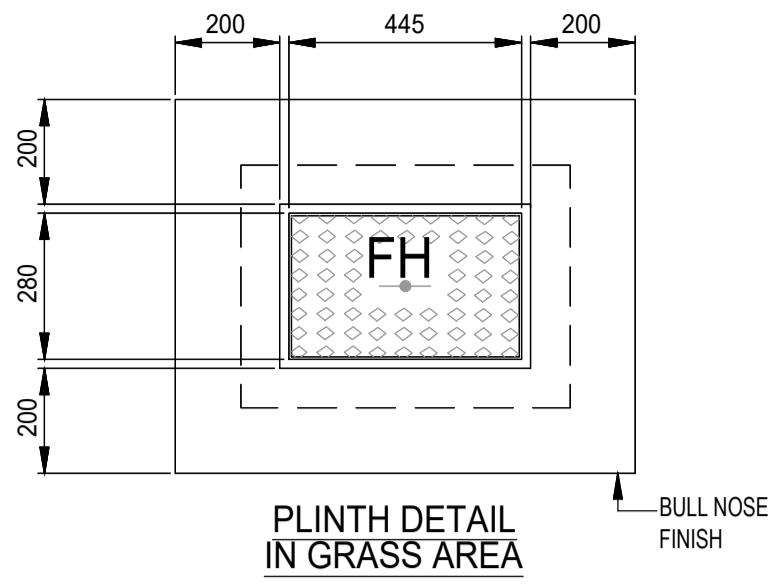
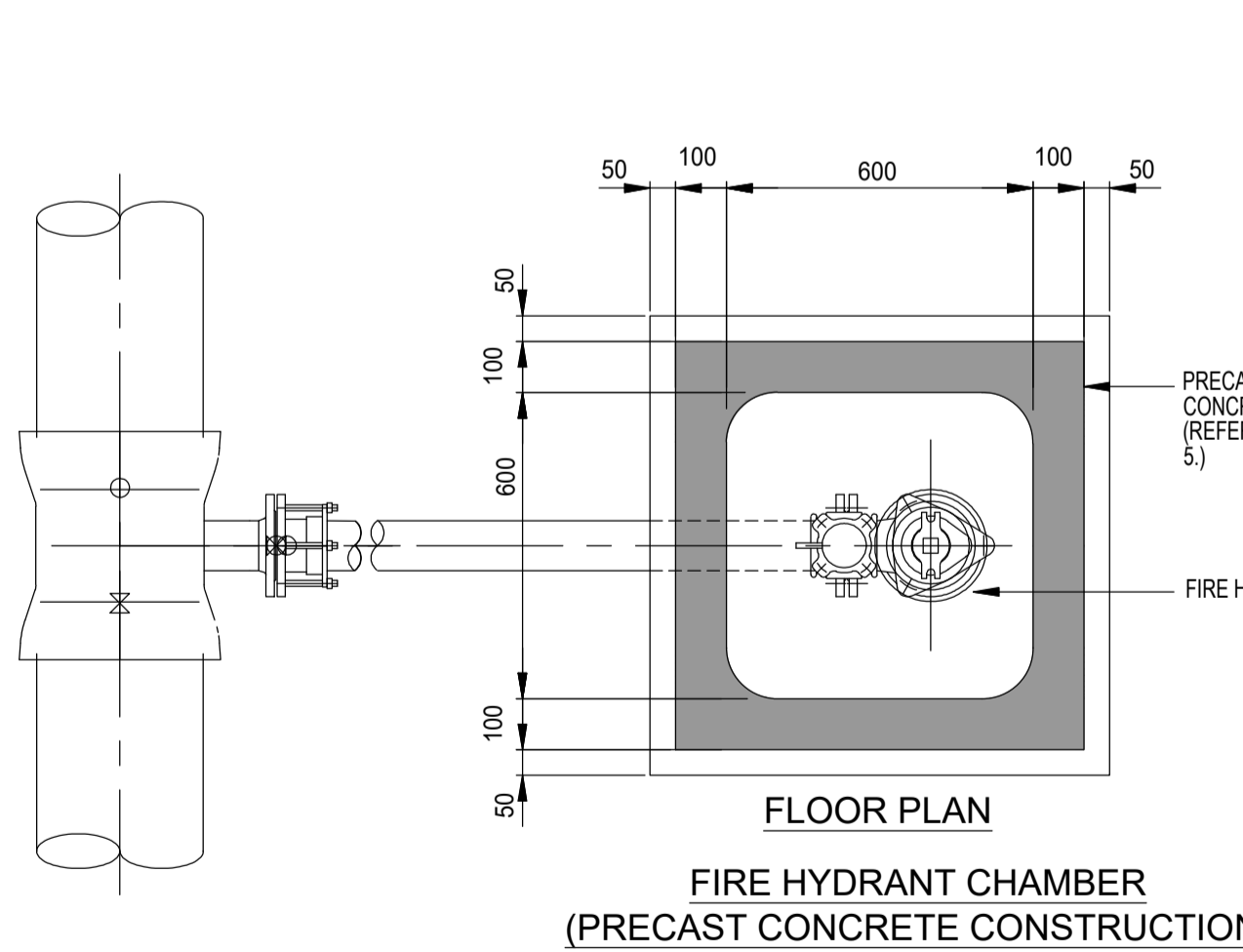
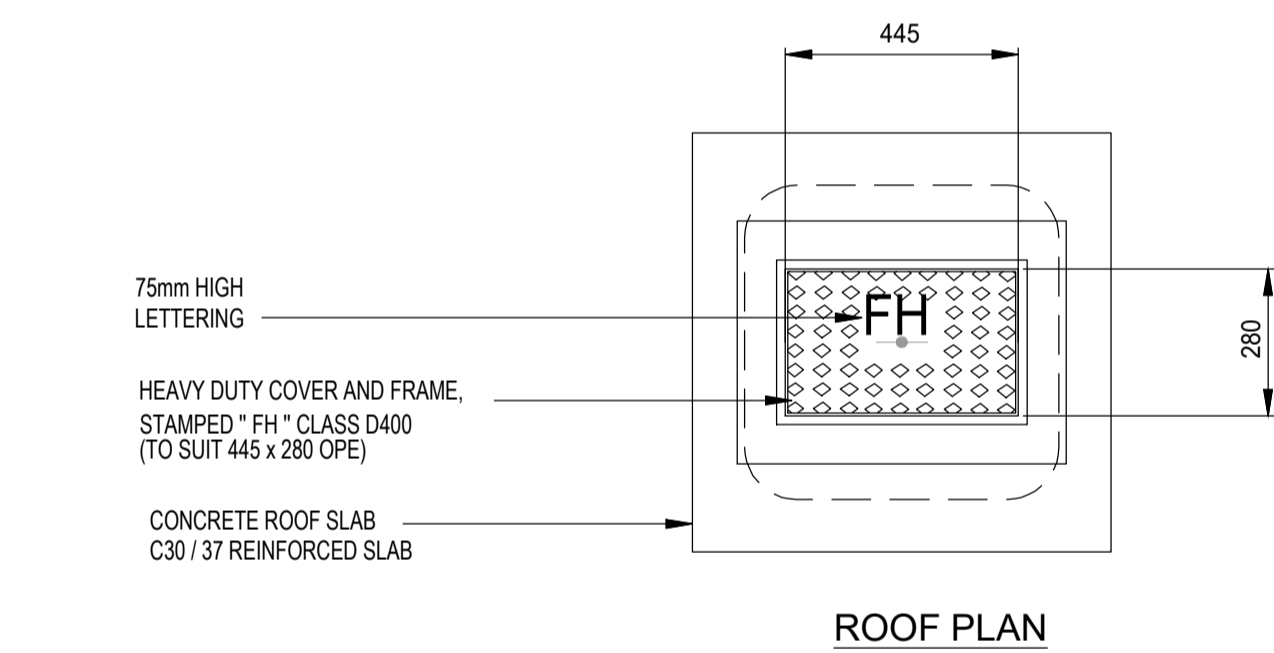
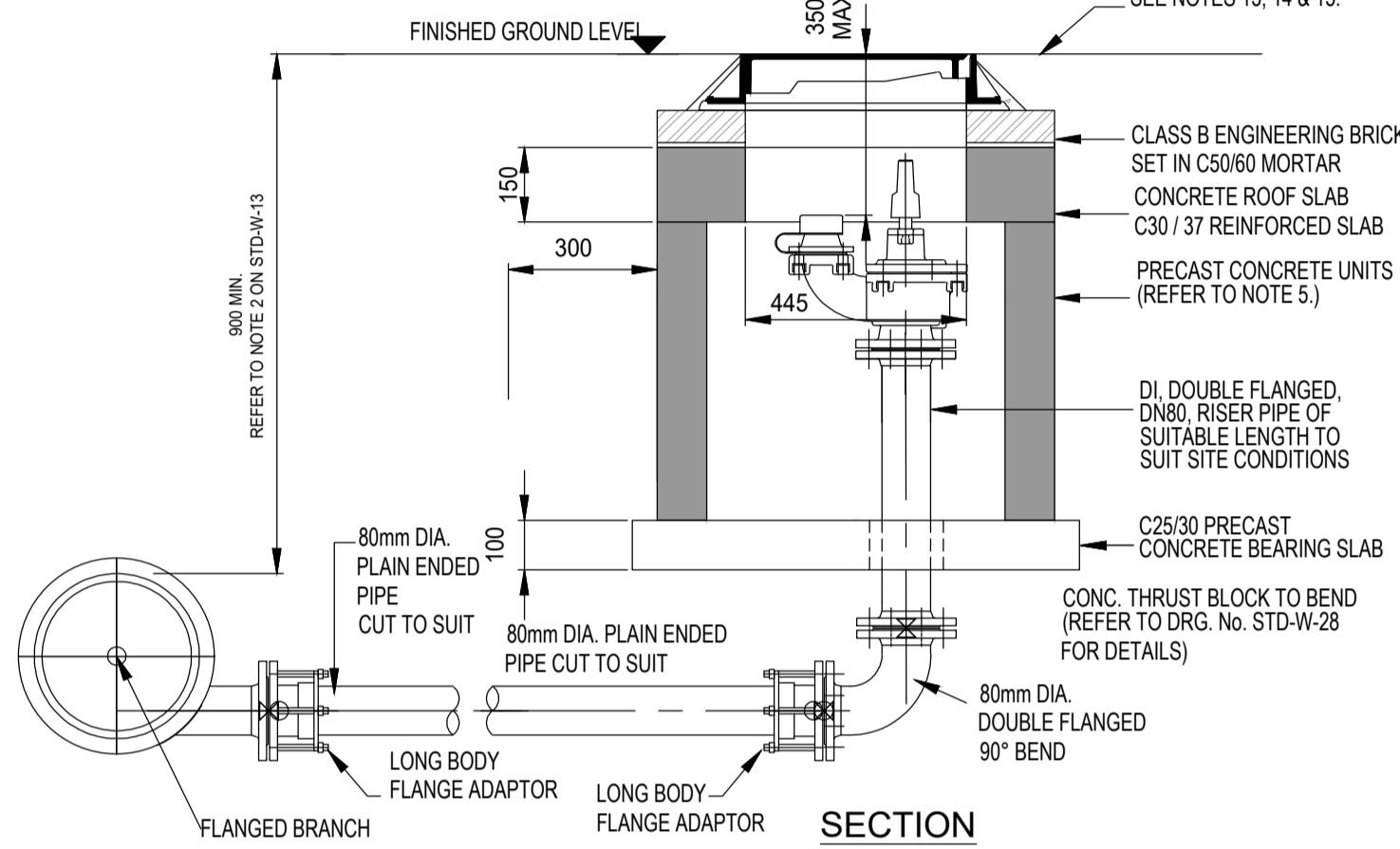

IRISH WATER DETAIL STD-W-19
OFF LINE HYDRANT FOR POLYETHYLENE (P.E.) PIPE
SCALE: N.T.S.

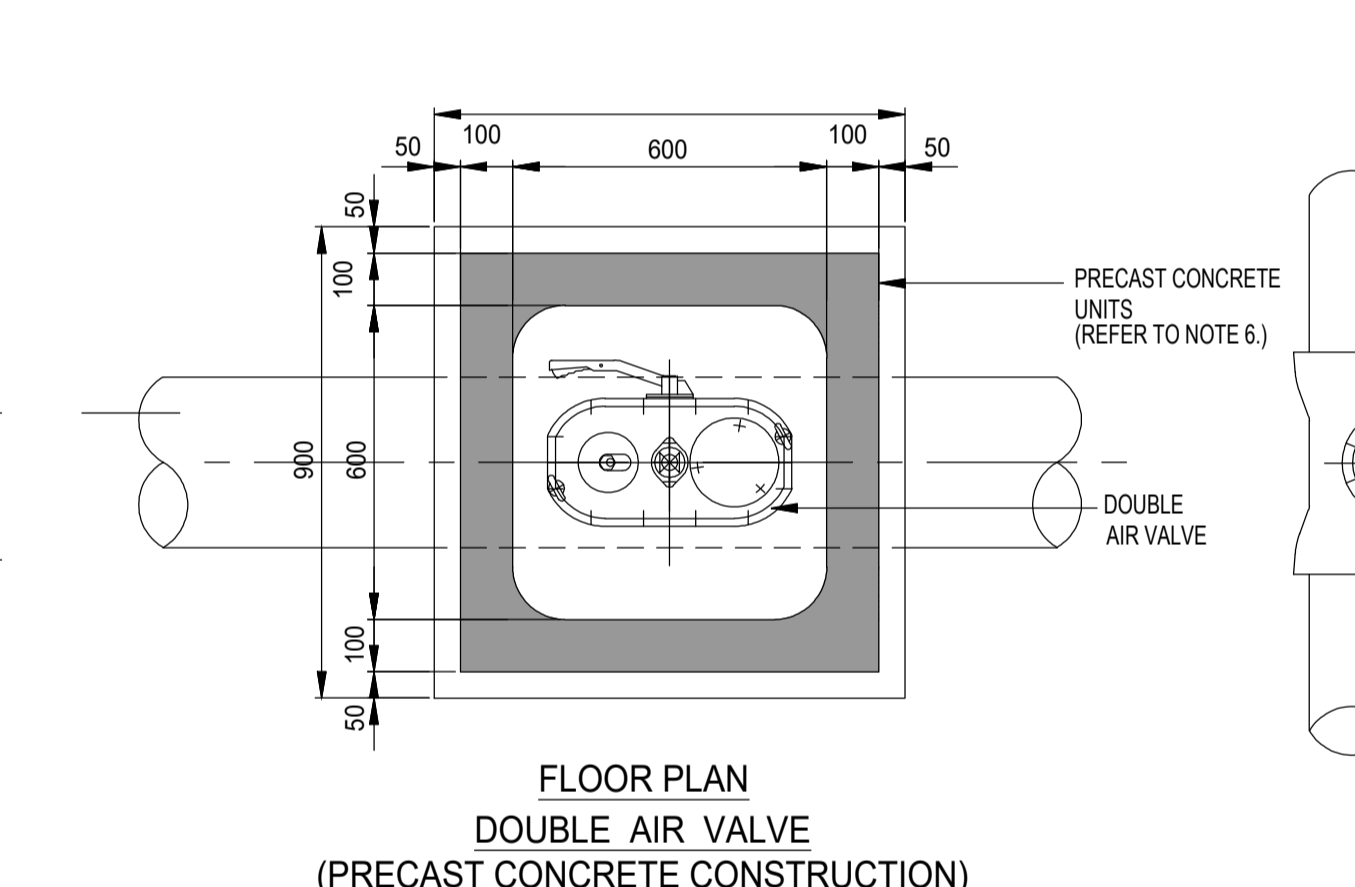
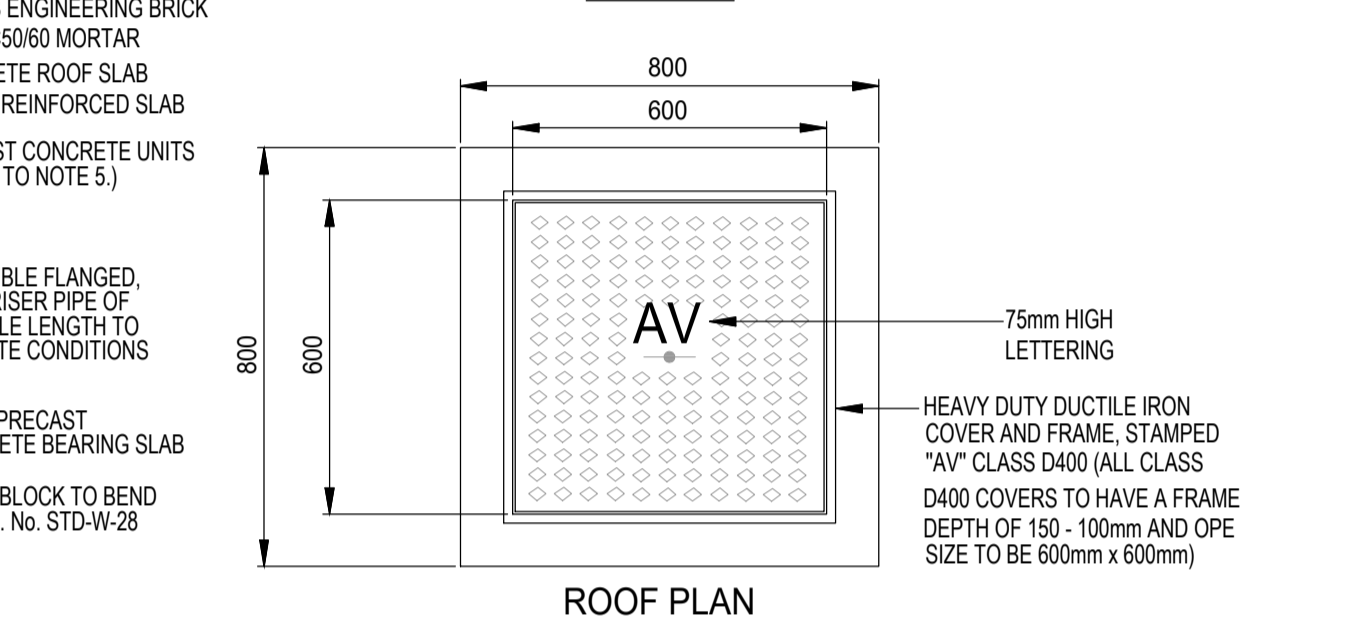
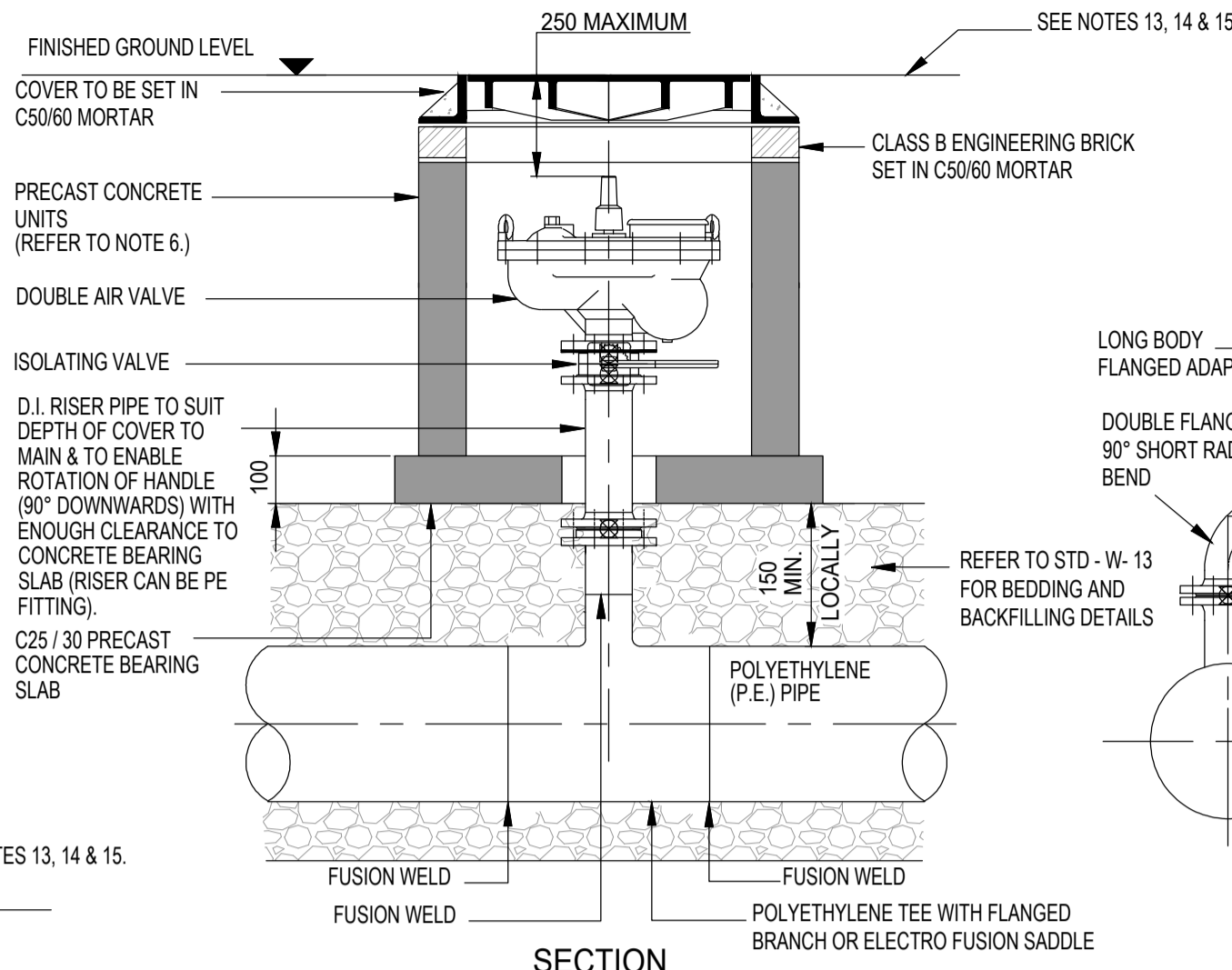

DIAMETER OF MAIN	UP TO 250 (mm)	250 TO 350 (mm)
DIAMETER OF BRANCH	80mm	100mm
BORE OF VALVE INLET	80mm	100mm

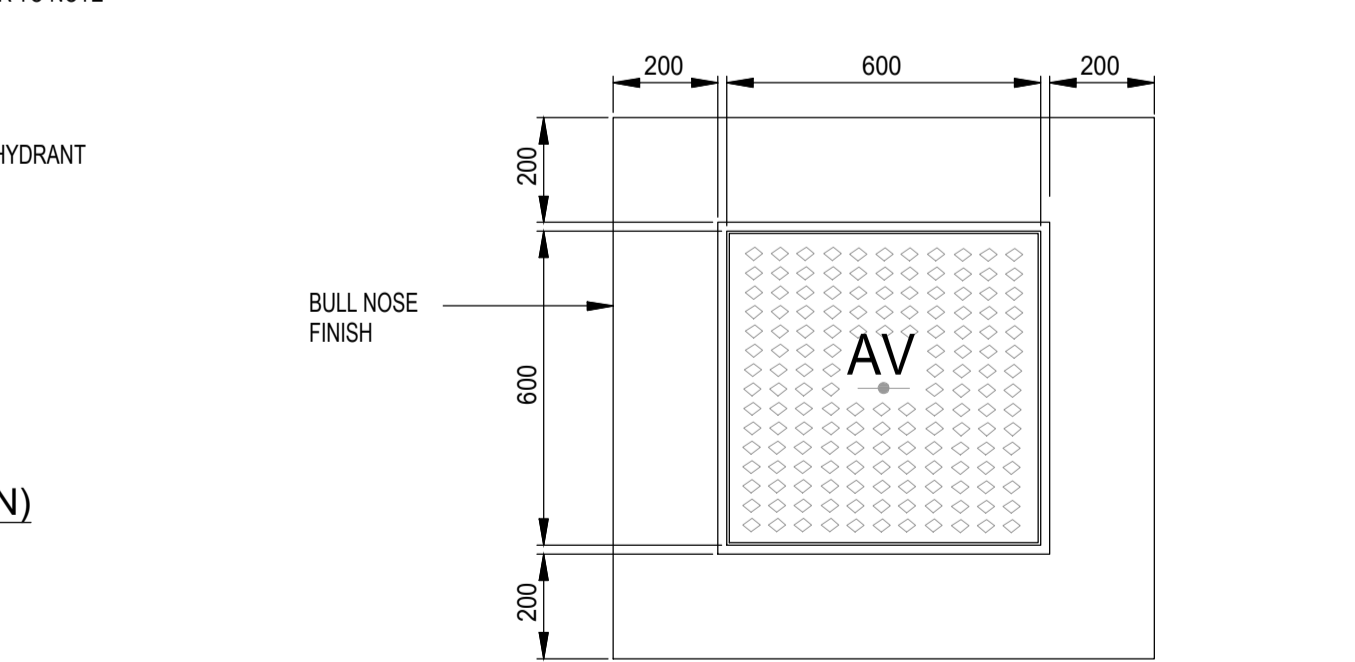

IRISH WATER DETAIL STD-W-22
ON LINE AIR VALVE FOR POLYETHYLENE (P.E.) PIPE
SCALE: N.T.S.

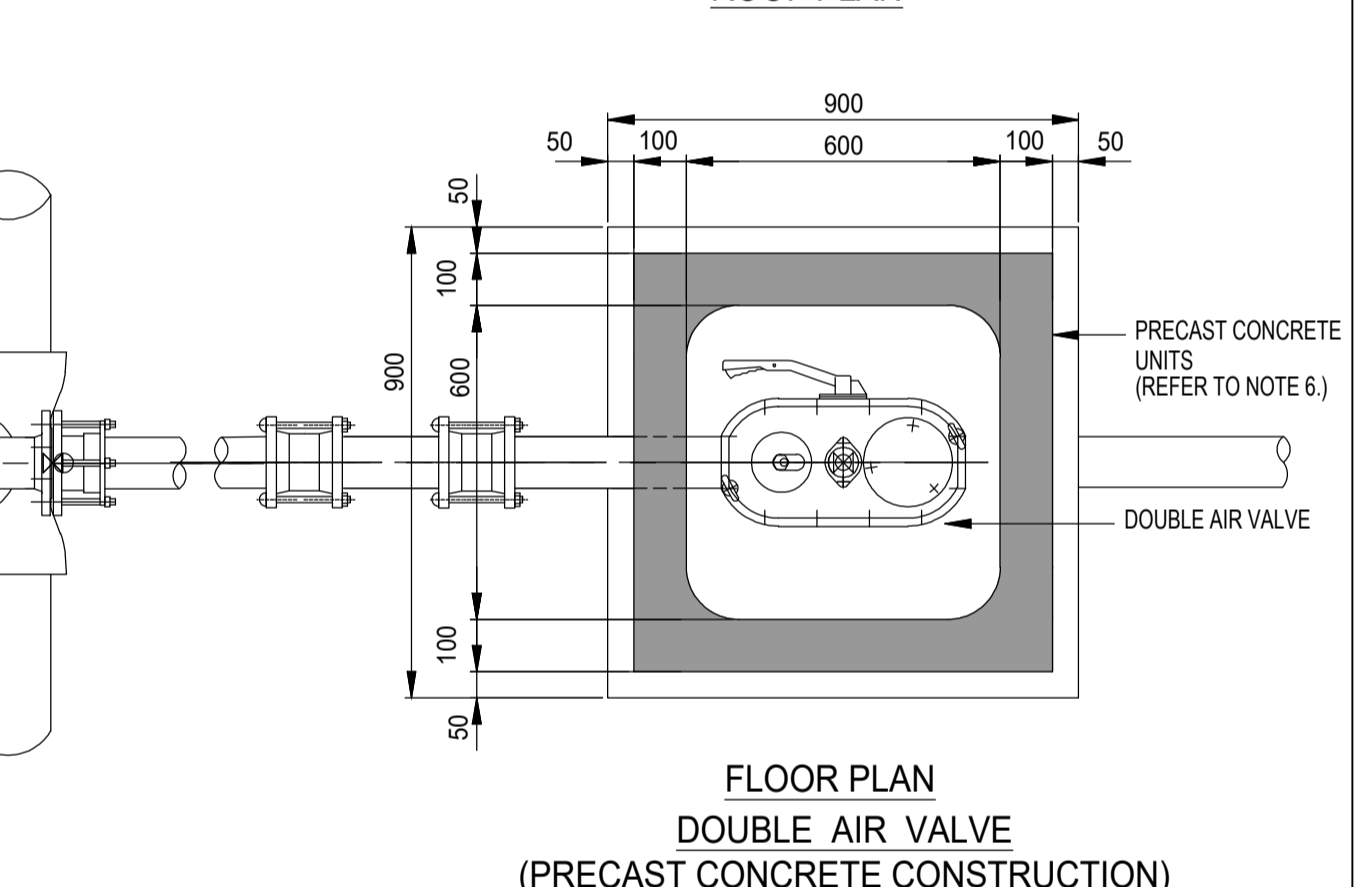
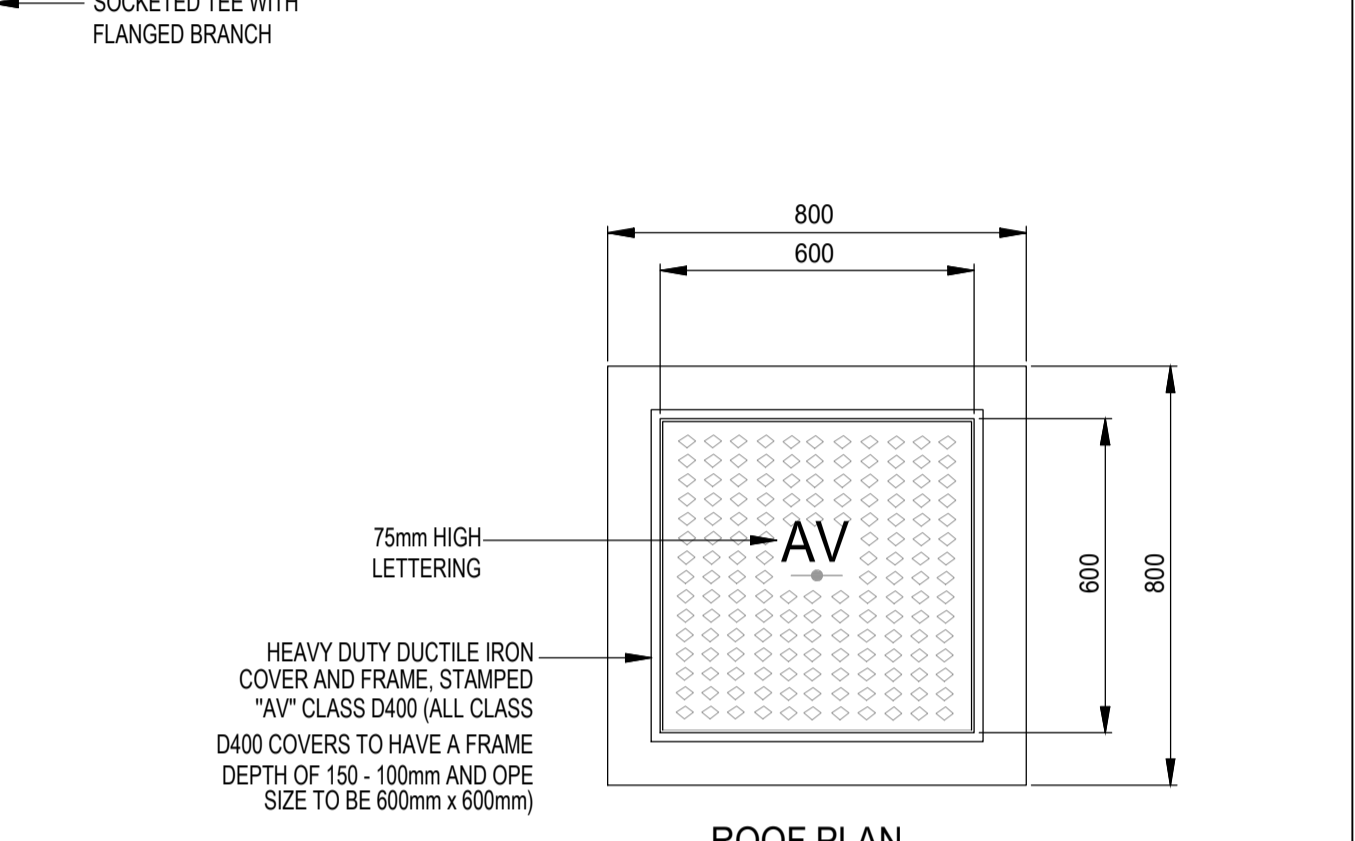
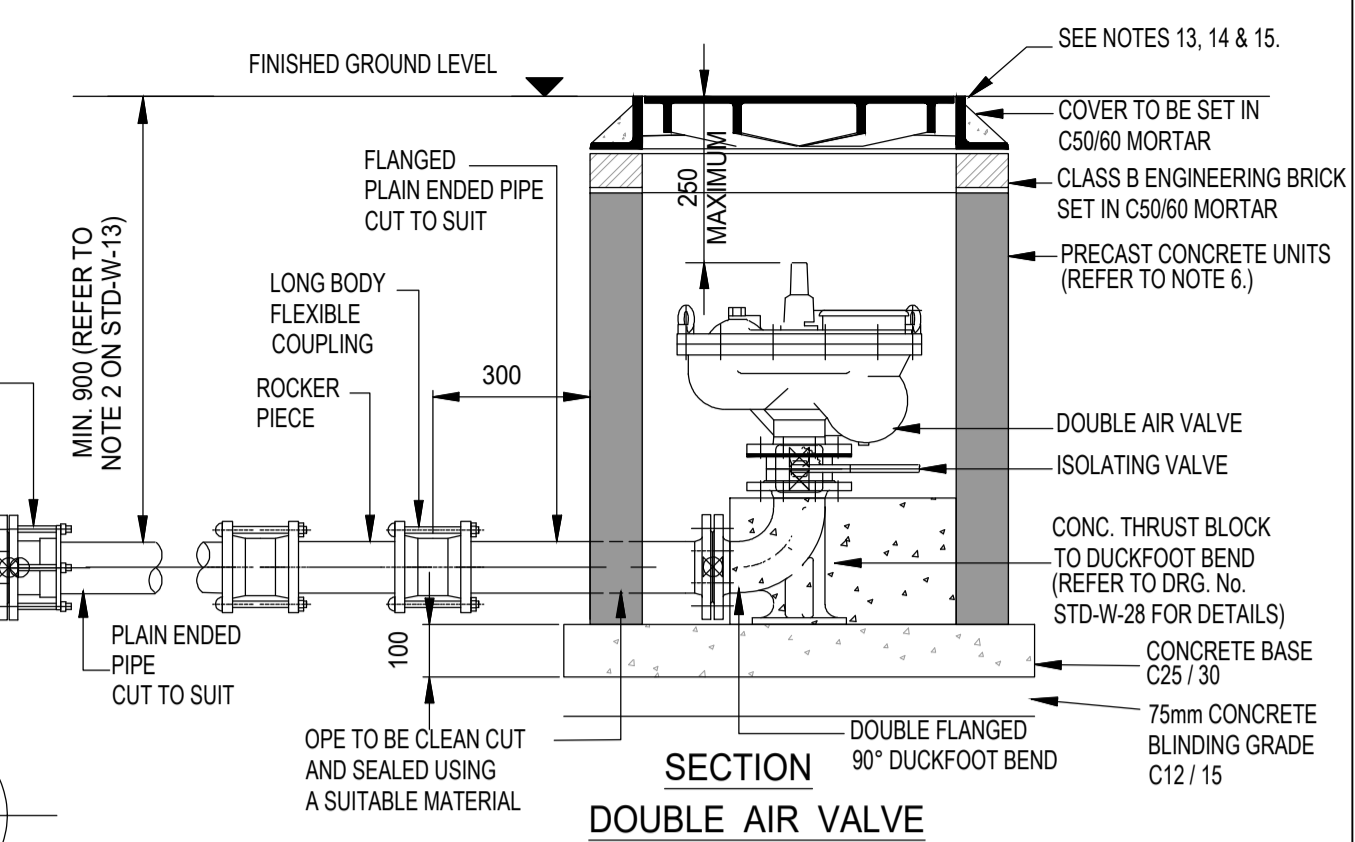

IRISH WATER DETAIL STD-W-23
OFF LINE AIR VALVE FOR POLYETHYLENE (P.E.) PIPE
SCALE: N.T.S.

ON LINE AIR VALVE NOTES

1. ALL DIMENSIONS IN MILLIMETRES (mm) UNLESS NOTED OTHERWISE.
2. AIR VALVE CHAMBERS SHALL BE COVERED WITH APPROVED VENTILATED HEAVY DUTY DUCTILE IRON COVERS TO IS EN 124 RATING D400. COVER AND FRAME SHALL BE SUITABLE FOR ROAD AND TRAFFIC CONDITIONS AND IS SUBJECT TO REVIEW BY IRISH WATER.
3. AIR VALVES SHALL COMPLY WITH THE REQUIREMENTS OF IS EN 1074-4. AIR VALVES SHALL BE DOUBLE ORIFICE TYPE AND SHALL INCLUDE AN ISOLATING VALVE. THE ISOLATING VALVE SHALL BE EITHER A GATE VALVE CONFORMING TO IS EN 1074-2 & SHALL BE OF A BOLTLESS BONNET DESIGN, OR A BUTTERFLY VALVE TO IS EN 1074-2.
4. SERVICE CONNECTIONS SHALL NOT BE PROVIDED WITHIN 2m OF THE AIR VALVE LOCATION. AIR VALVE CHAMBERS TO BE OF PRECAST CONCRETE UNITS OR HIGH DENSITY BLOCKWORK. ALTERNATIVE PROPRIETARY PREFABRICATED CHAMBER UNITS MAY ALSO BE USED. SUBJECT TO REVIEW BY IRISH WATER.
5. PRECAST CONCRETE CHAMBERS SHALL BE SURROUNDED BY A MINIMUM OF 150mm COMPACTED CLAUSE 808 MATERIAL AS PER STD-W-13.
6. DUCTILE IRON PIPES / FITTINGS AND PE PIPES / FITTINGS TO BE IN ACCORDANCE WITH IS EN 545 AND IS EN 12201:2011.
7. 200mm ALL AROUND, 100mm DEEP CONCRETE PLINTH AROUND COVERS IN GREEN AREAS.
8. THRUST BLOCKS (NOT SHOWN ON DRAWING), TO BE PROVIDED AS PER STANDARD DRAWING STD-W-28 AT ALL TEES, BENDS, TAPERS, DEAD ENDS AND PIPES AT STEEP SLOPES.
9. ANTI CORROSION TAPE TO BE PROVIDED AROUND BURIED FLANGES.
10. THE LOCATION OF THE AIR VALVE SHALL BE THE SUBJECT OF PARTICULAR AGREEMENT WITH IRISH WATER TO ENSURE THAT THE RISK OF CONTAMINATION THROUGH THE VALVE IS ELIMINATED.
11. ALL CONCRETE TO BE IN ACCORDANCE WITH IS EN 206.
12. ANY SPECIAL ROAD REINSTATEMENT AROUND COVER & FRAME SHALL BE TO ROAD AUTHORITY'S REQUIREMENTS.
13. NEW ROAD CONSTRUCTION & SURFACE FINISH TO BE TO ROAD AUTHORITY REQUIREMENTS.
14. EXISTING ROAD REINSTATEMENT TO COMPLY WITH CURRENT VERSION OF "GUIDELINES FOR MANAGING OPENINGS IN PUBLIC ROADS" BY THE DEPT. OF TRANSPORT, TOURISM & SPORT, OR TRANSPORT INFRASTRUCTURE IRELAND REQUIREMENTS.

GENERAL NOTES:-

1. THIS DRAWING TO BE READ IN CONJUNCTION WITH ALL RELEVANT ARCHITECTS & ENGINEERS DRAWINGS & SPECIFICATIONS.
2. DO NOT SCALE. USE FIGURED DIMENSIONS ONLY.
3. THE CONTRACTOR SHALL VERIFY ALL DIMENSIONS & ELEVATIONS WITH ARCHITECTURAL DRAWINGS PRIOR TO START OF CONSTRUCTION. ALL DISCREPANCIES TO BE NOTIFIED, IN WRITING TO ENGINEERS & ARCHITECTS FOR RESOLUTION.
4. ALL DIMENSIONS ON DRAWINGS ARE IN MILLIMETRES UNLESS OTHERWISE NOTED.
5. FOR DETAILS AND SETTING OUT OF RWP, SVP, WVP & ALL OPENINGS SEE THE RELEVANT ARCHITECTS DRAWINGS.
6. FOR RADON BARRIER, D.P.C. & INSULATION DETAILS REFER TO ARCHITECTS DRAWINGS.

NOTE: DETAILS PROVIDED ARE IN ACCORDANCE WITH IRISH WATER DOCUMENT "WATER INFRASTRUCTURE STANDARD DETAILS, CONNECTIONS AND DEVELOPER SERVICES", CONSTRUCTION REQUIREMENTS FOR SELF LAY DEVELOPMENTS DECEMBER 2017 (REVISION 03) DOCUMENT NUMBER IW-CDS-5030-01

NOTE: ALL WORKS SHALL BE DESIGNED AND CONSTRUCTED IN ACCORDANCE WITH THE IRISH WATER CODE OF PRACTICE DOCUMENT IW-CDS-5020-03 AND THE IRISH WATER STANDARD DETAILS IW-CDS-5020-01

NOTE: THIS DOCUMENT IS LIABLE TO CHANGE IT IS THE CONTRACTORS RESPONSIBILITY TO ENSURE THAT THE DETAILS USED ON SITE ARE IN ACCORDANCE WITH THE MOST RECENT REVISION OF THE IRISH WATER STANDARDS.

Issue Register

No.	Date	Description	Drawn	Checked	Approved
PL1	12/03/21	PLANNING ISSUE	RDS	EJQ	M.P.

PLANNING

Client: KILKENNY COUNTY COUNCIL

Project: FIRE STATION, URLINGFORD, CO. KILKENNY

Drawing Title: PROPOSED WATERMAIN DETAILS SHEET 2

Project No: 191009 Scale: A1 - VARIOUS

Drawing No: 191009/C/033 Rev: PL1

Drawn: RDS Checked: EJQ Date: 08/02/21

Martin Peters Associates Consulting Engineers

Office: 100, Main Street, Kilkenny, Co. Kilkenny, Ireland

T: +353 51 772211 E: info@mpa.ie W: www.mpa.ie